

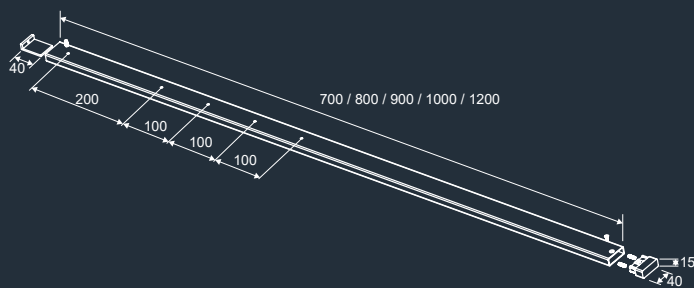

unidrain®



TOP RAIL 5310

DK | MONTERINGSVEJLEDNING

UK | INSTALLATION GUIDE

PL | PODRĘCZNIK INSTALACJI

DK | INDHOLD
 UK | CONTENTS
 PL | ZAWARTOŚĆ

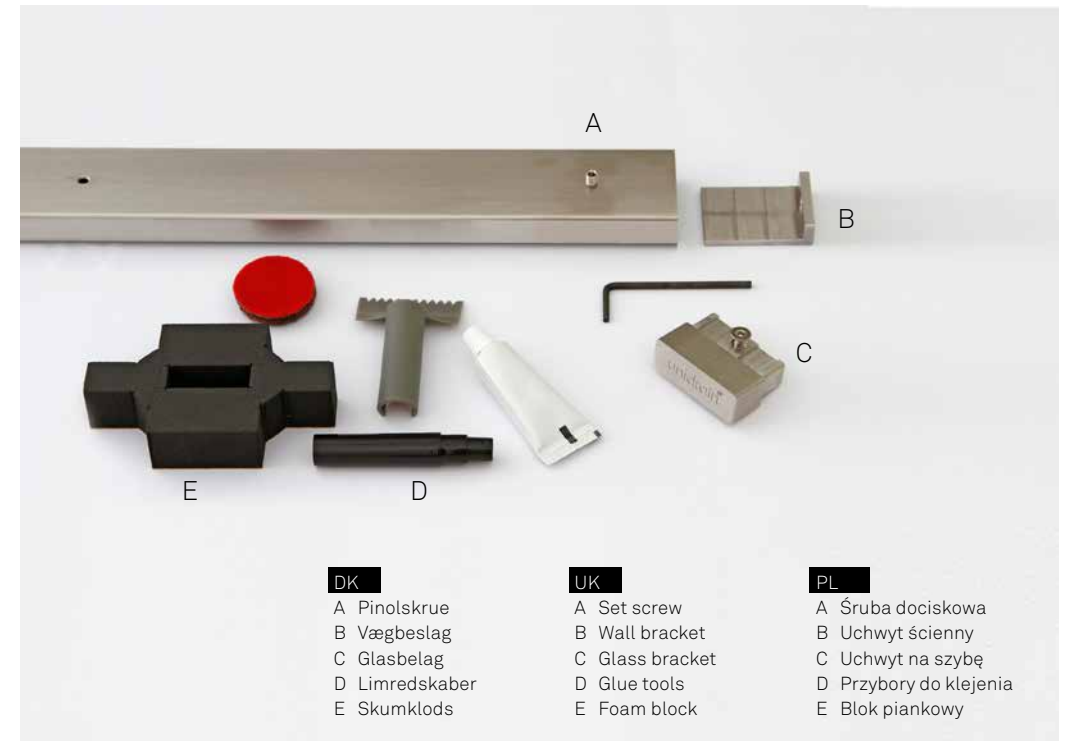

DK | DIMENSIONER
 UK | DIMENSIONS
 PL | WYMIARY

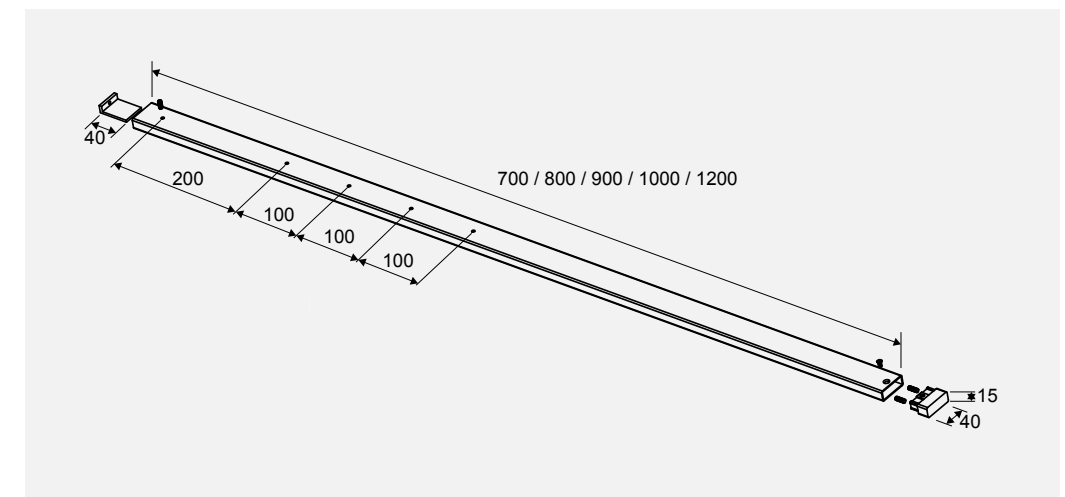



OM GLASSLINE TOPSTANG

Topstangen fås i både rustfrit stål og glas og er en stilfuld tilføjelse til GlassLine brusevæggen.





Som afslutning på GlassLine brusevæg på 1200 mm anbefales topstangen til stabilisering.



Topstangen skal ydermere bruges ved montering af GlassLine brusedør.

Topstangen i rustfrit stål findes i én længde der skæres til i den ønskede længde.

Topstangen passer dermed til alle de gængse unidrain® mål 700/800/900/1000/1200.

FORBEREDELSE

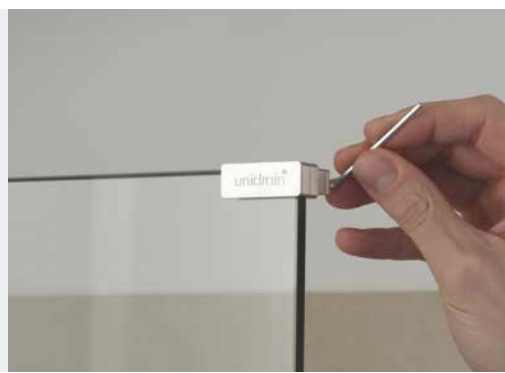
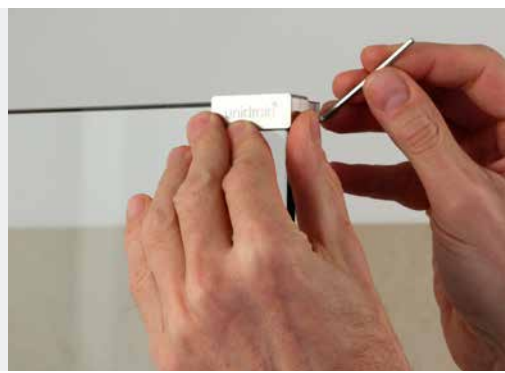
1		<p>På GlassLine brusevæggen sidder et unidrain® logo, som skal afmonteres, før det videre arbejde fortsættes.</p>
2		<p>unidrain® logoet er limet fast med silikone. Silikonen skæres forsigtigt løs med en hobbykniv (OBS: Pas på ikke at ridse glasset).</p>
3		<p>Når det lille emblem er skåret løst, kan det enten lirkes af eller forsigtigt slås af med en træklods.</p>
4		<p>Afslutningsvis kan eventuel resterende silikone fjernes med silikonefjerner.</p>

5		<p>Glasbeslaget til topstangen placeres på hjørnet af brusevæggen og spændes til med de to pinolskruer, der sidder i beslaget.</p>
6		<p>OBS: Stram skruerne til der er modstand og så en kvart omgang mere. Så er beslaget fastgjort</p>
7		<p>Rens fliserne med en klud, hvor vægbeslaget til topstangen skal sidde, inden de næste trin udføres.</p>

TILPASNING AF TOPSTANGENS LÆNGDE

8

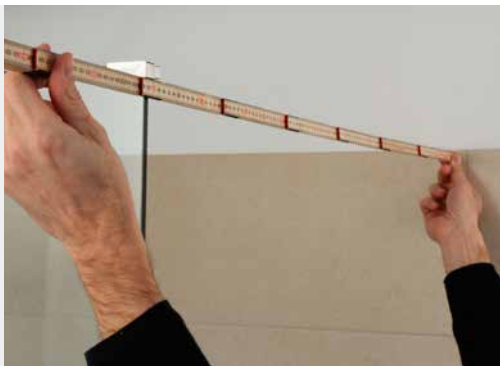

Mål afstanden fra glasbeslaget til flisevæggen på modsatte side.

9



Det nøjagtige sted, hvor topstangen skal sidde, bruges, når der måles op.

10

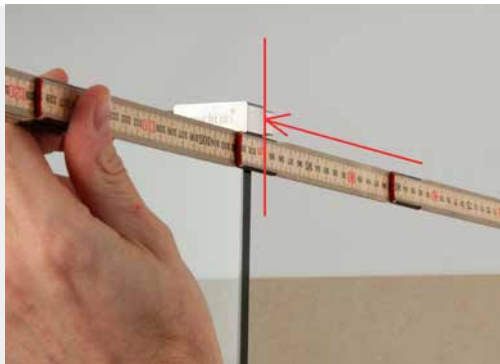

Mål kun hen til stedet, hvor topstangen skal sidde i galsbeslaget.

11



Afsæt målet på topstangen.

12

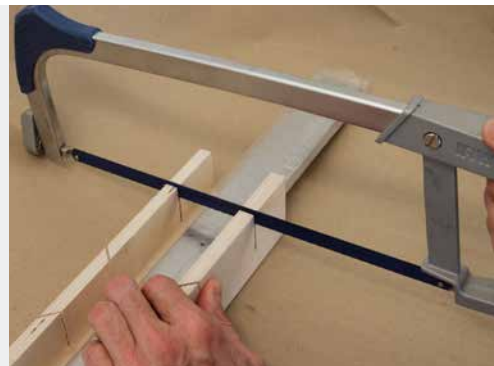

Skær topstangen til med en nedstryger og gerne i en "skærekasse" (OBS: Pas på ikke at ridse stålet).

13



Fil enden af topstangen for at sikre en lige og pæn afslutning.

AFMÆRKNING AF ENDELIG POSITION

14



Mål dybden af brusenichen fra fliserne på væggen til unidrain® glasbeslaget.

15



Mål til ydersiden af den kraftige del af glasbeslaget.

16



Afsæt målet på den modsatte side af brusenichen.

17

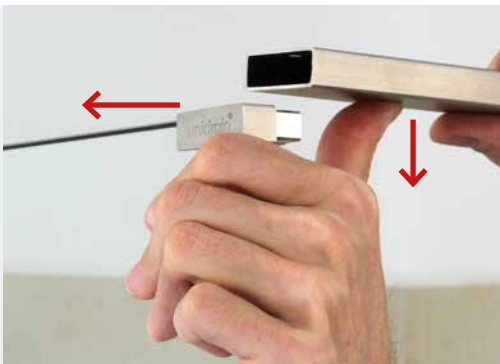

Placer den afskårede topstang i glasbeslaget, ved at trække brusevæggen til siden, så stangen kan komme forbi og i position.

18



Hold topstangen vandret ved hjælp af et vaterpas og afsæt mærker på fliserne rundt om topstangen.

19



Afmærkning til placering af skumklodsen.

20

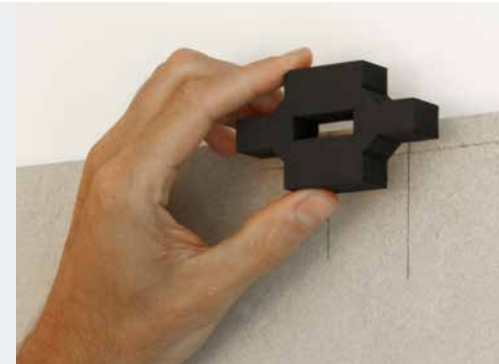

Fjern filmen på skumklodsen og sæt klodsen fast på fliserne.

21

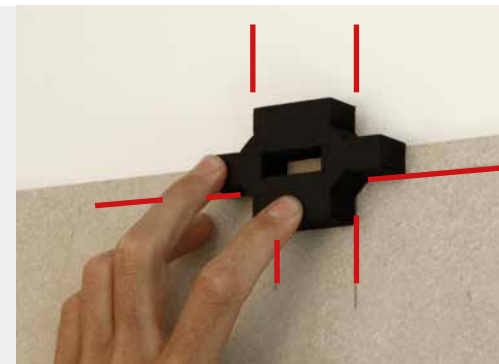

Placer skumklodsen i forhold til stregerne.

FASTKLÆBNING AF VÆGBESLAG PÅ FLISER

22



Vægbeslaget renses grundigt med vedlagte skumbørste.

23



Håndsprayen anvendes som rensesvæske.

24



Tør beslaget grundigt, inden limen påføres.

25



Påfør limen i et ca. 3-5mm tykt lag.



MONTERING PÅ ANDRE OVERFLADER END FLISER

Det er muligt at skrue vægbeslaget fast, hvis det ønskes. Monteres topstangen på en vægoverflade, der ikke kan bære trækket fra limen, som f.eks. malede overflader, er dette et krav.

26



Ved hjælp af den lille "rive" trækkes spor igennem limen.

27



Brug håndsprayen til at aktivere limen ved at spraye væske direkte på limen.

28



Træk "riven" gennem lim og væske på tværs et par gange for at sikre, at de to materialer bliver blandet.

29

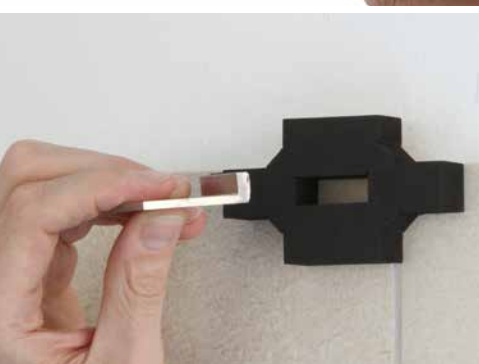

Tryk vægbeslaget fast på fliserne gennem hullet i skumklodsen. Skumklodsen holder beslaget på plads, mens limen tørrer.

NB: Den fulde tørretid er 72 timer, men stangen kan forsigtigt færdigmonteres allerede efter 24 timer.

FÆRDIGMONTERING

30



Når skumklodsen afmonteres, kan der sidde lidt overskydende limrester, som skal fjernes med en skraber eller en hobbykniv.

31



Topstangen skydes forsigtigt ind over vægbeslaget.

32

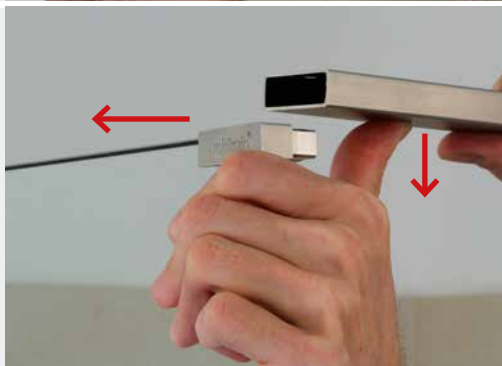

Træk ud i brusevæggen så stangen kan komme på plads.

33

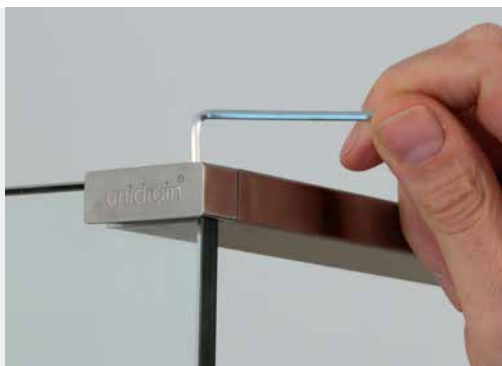

Spænd topskruen.

34



I den anden ende sættes pinolskruen i og fastspændes.

35



Topstangen er færdigmonteret.



ABOUT GLASSLINE TOP RAIL

The top rail is available in both stainless steel and glass and adds a stylish touch to the GlassLine shower screen.

A top rail is recommended to stabilise a 1200 mm GlassLine shower screen.

The top rail must also be used when installing a GlassLine shower door.

The stainless steel top rail is available in one length and can be cut to the desired length.

The top rail thereby fits all the common unidrain® sizes: 700/800/900/1000/1200.

PREPARATION

1



The GlassLine shower screen has a unidrain® logo that must be removed before continuing with the installation.

2



The unidrain® logo is glued on with silicone. Carefully cut the silicone loose using a utility knife (NOTE: Be careful not to scratch the glass).

3



When the small emblem has been cut loose, it can either be pried off or gently hammered off using a wooden block.

4



Lastly, any remaining silicone can be removed using silicone remover.

5

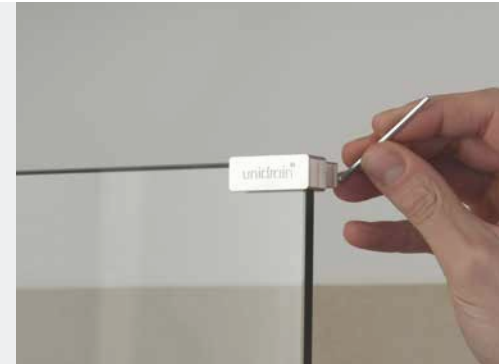

Place the glass bracket for the top rail on the corner of the shower screen and tighten it in place with the two set screws in the bracket.

6

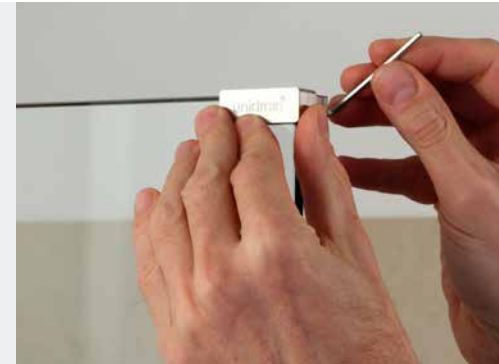

NOTE: Tighten the screws until there is resistance, and then a quarter turn more. The bracket is then attached in place.

7



Before performing the next steps, clean the tiles with a cloth where the wall bracket for the top rail will be placed.

ADJUSTING THE LENGTH OF THE TOP RAIL

8

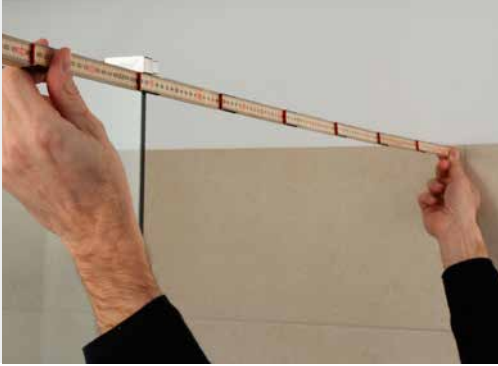

Measure the distance from the glass bracket to the tile wall on the opposite side.

9



Use the exact place where the top rail will be installed when measuring.

10

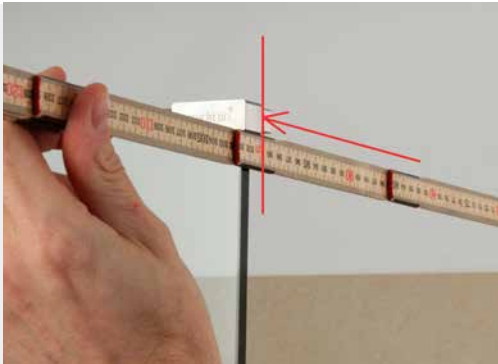

Only measure to the point where the top rail will rest in the glass bracket.

11



Mark the measurement on the top rail.

12

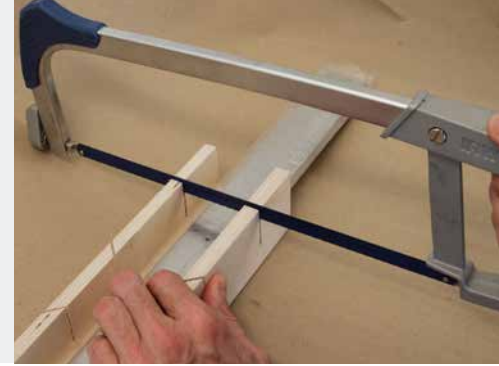

Cut the top rail with a hacksaw and preferably using a mitre box (NOTE: Be careful not to scratch the steel).

13



File the end of the top rail to ensure a straight and clean finish.

MARKING THE FINAL POSITION

14



Measure the depth of the shower cubicle from the tiles on the wall to the unidrain® glass bracket.

15



Measure to the outside of the thick part of the glass bracket.

16



Mark the measurement on the opposite side of the shower cubicle.

17

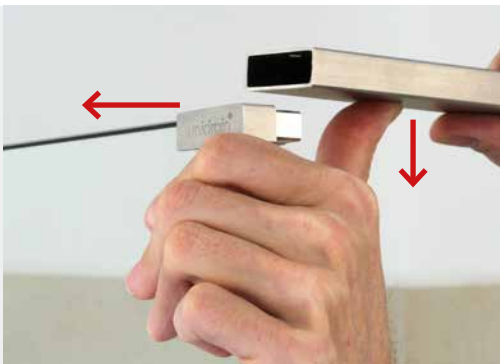

Place the cut top rail in the glass bracket by pulling the shower screen to the side so that the rail can slip into position.

18



Hold the top rail horizontally using a spirit level and mark the tiles around the top rail.

19



Marking the location of the foam block.

20

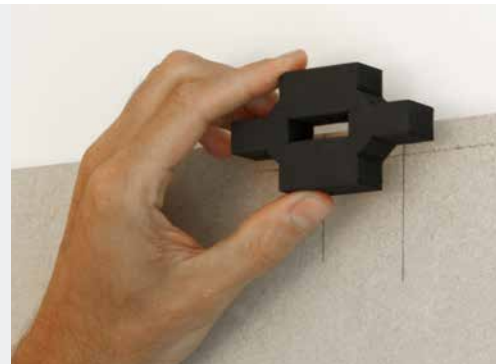

Remove the film on the foam block and fix the block to the tiles.

21

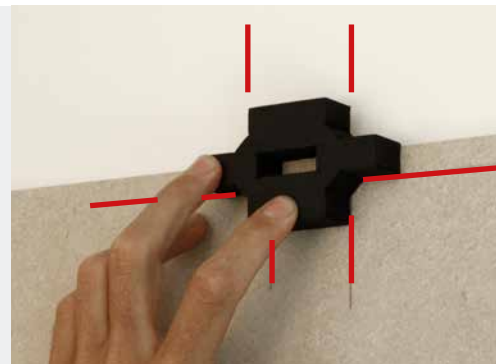

Place the foam block according to the markings.

ADHESION OF WALL BRACKET TO TILES

22



Clean the wall bracket thoroughly using the enclosed foam brush.

23



Use the hand spray as a cleaning fluid.

24



Dry the bracket thoroughly before applying the glue.

25



Apply the glue in a layer approximately 3-5mm thick.



INSTALLATION ON OTHER SURFACES THAN TILES

It is possible to screw the the wall bracket in place if desired. If the top rail is installed on a wall surface to which the glue cannot stick, such as painted surfaces, using screws is required.

26



Using the small "rake", drag tracks through the glue.

27



Use the hand spray to activate the glue by spraying the fluid directly on the glue.

28



Drag the "rake" across the glue and fluid a couple of times to ensure that the two materials are mixed together.

29



Press the wall bracket against the tiles through the hole in the foam block. The foam block will hold the bracket in place while the glue dries.
NOTE: The full drying time is 72 hours, but the rail can be carefully installed after just 24 hours.

COMPLETING THE INSTALLATION

30



When the foam block is removed, there may be some excess glue residue that must be removed with a scraper or a utility knife.

31



Slide the top rail carefully on top of the wall bracket.

32

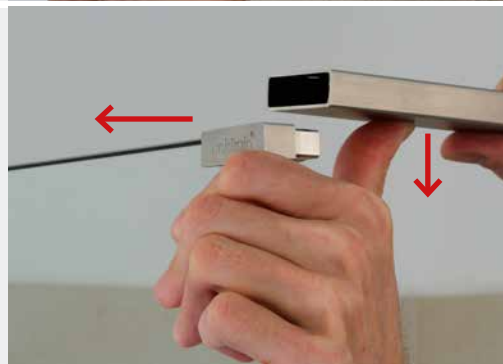

Pull out the shower screen so that the rail can slot into place.

33

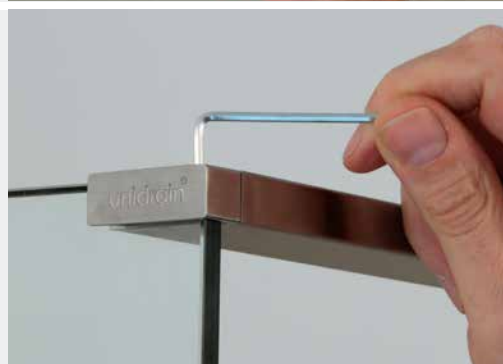

Tighten the top screw.

34

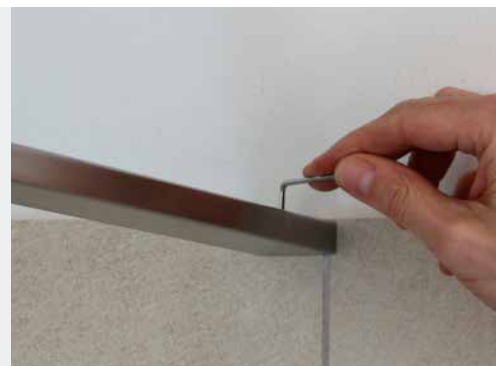

On the other end, insert the set screw and tighten.

35



The top rail is now installed.



INFORMACJE O GÓRNEJ SZYNIE GLASSLINE

Górna szyna dostępna w wersji ze stali nierdzewnej oraz szkła stanowi stylowe wykończenie ściany prysznicowej GlassLine.



Zaleca się stosowanie górnej szyny do stabilizowania ścian prysznicowych GlassLine 1200 mm. Górna szyna jest również konieczna w przypadku montażu drzwi kabiny prysznicowej GlassLine.

Górna szyna ze stali nierdzewnej dostępna jest w jednym wymiarze, ale można ją przyciąć do żądanej długości.

Można ją więc stosować ze wszystkimi typowymi wymiarami unidrain®: 700/800/900/1000/1200.

PRZYGOTOWANIE

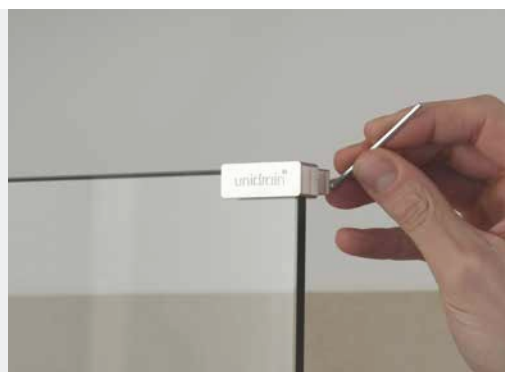
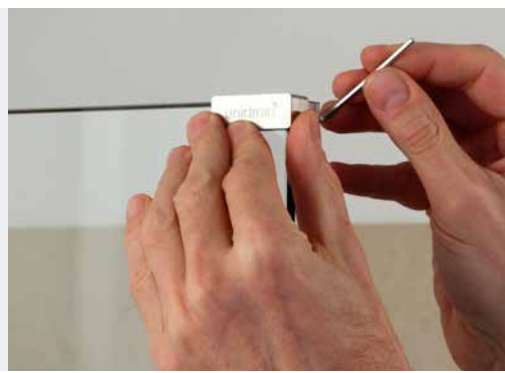
1		<p>Ściana prysznicowa GlassLine ma logo unidrain®, które trzeba usunąć przed rozpoczęciem montażu.</p>
2		<p>Logo unidrain® jest przyklejone silikonem. Ostrożnie odciąć silikon nożem z łamanym ostrzem (UWAGA: zachować ostrożność, aby nie porysować szyby).</p>
3		<p>Po odcięciu maty element zawierający logo można podważyć lub delikatnie podbić za pomocą młotka i listewki.</p>
4		<p>Pozostały silikon można usunąć za pomocą środka do usuwania silikonu.</p>

5		<p>Umieścić uchwyt na szybę do mocowania górnej szyny na narożniku ściany prysznicowej i dokręcić, korzystając z dwóch śrub dociskowych.</p>
6		<p>UWAGA: Dokręcić śruby do wycucia oporu, a potem jeszcze o ćwierć obrotu. Uchwyt jest teraz zamocowany na swoim miejscu.</p>
7		<p>Przed przejściem do kolejnych kroków wyczyścić szmatką glazurę w punkcie, gdzie zamocowany zostanie uchwyt ścienny górnej szyny.</p>

DOBIERANIE DŁUGOŚCI GÓRNEJ SZYNY

8

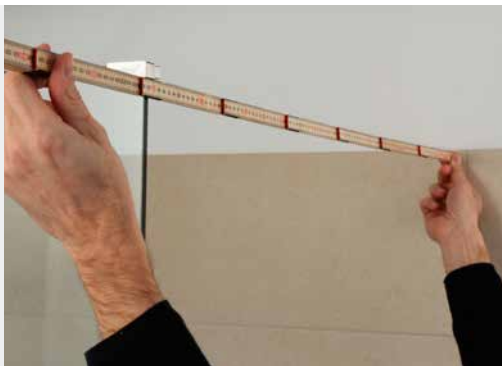

Zmierzyć odległość od uchwyty na szybę do przeciwległej ściany.

9



Pomiar należy wykonać dokładnie w miejscu, gdzie przymocowana zostanie górna szyna.

10

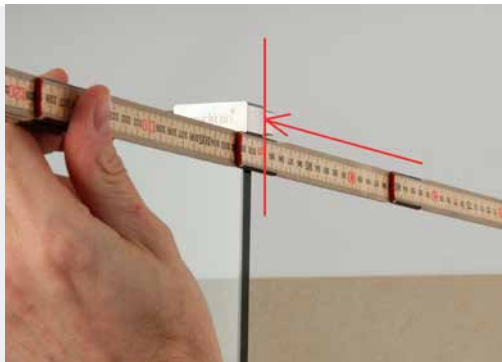

Zmierzyć tylko do punktu, gdzie górna szyna oprze się w uchwycie na szybę.

11



Oznaczyć długość na górnej szynie.

12

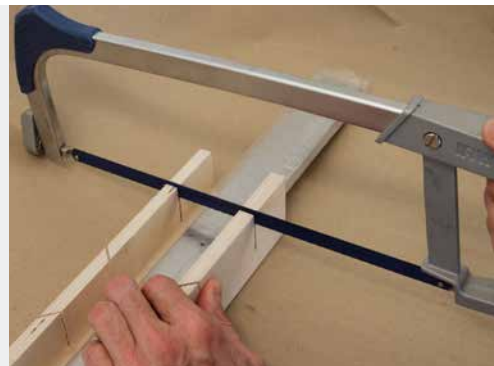

Przyciąć górną szynę piłą do metalu, najlepiej z wykorzystaniem skrzynki uciosowej (UWAGA: zachować ostrożność, aby nie porysować stali).

13



Pilnikiem wyrównać i oczyścić koniec górnej szyny.

OZNACZANIE USTAWIENIA KOŃCOWEGO

14



Zmierzyć głębokość kabiny prysznicowej od glazury na ścianie do uchwyty na szybę unidrain®.

15



Pomiar wykonać do zewnętrznej powierzchni grubszej części uchwyty na szybę.

16



Nanieść oznaczenia na przeciwnej ścianie kabiny prysznicowej.

17

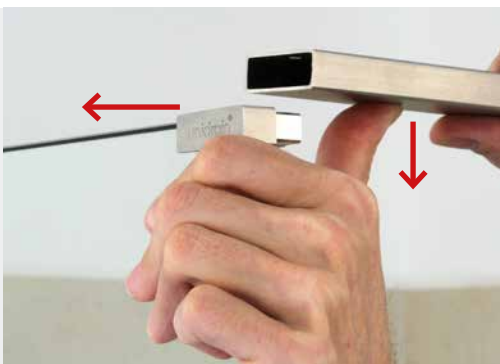

Umieścić przyciętą górną szynę w uchwycie na szybę poprzez odciągnięcie ściany prysznicowej w bok, tak aby umożliwić wsunięcie szyny w odpowiednie położenie.

18



Ustawić górną szynę poziomo z wykorzystaniem poziomicy alkoholowej i zaznaczyć glazurę wokół górnej szyny.

19



Oznaczenia do ustawienia bloku piankowego.

20

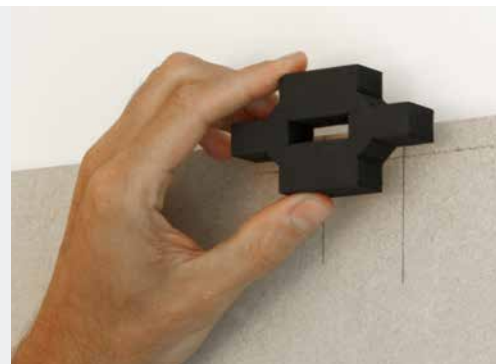

Odkleić folię z bloku piankowego i przymocować go do glazury.

21

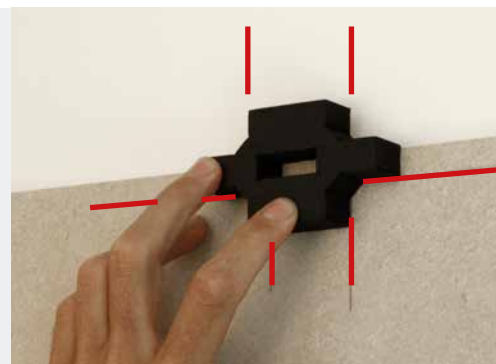

Ustawić blok piankowy zgodnie z oznaczeniami.

PRZYKLEJANIE UCHWYTU ŚCIENNEGO DO GLAZURY

22



Dokładnie oczyścić uchwyt ścienny za pomocą dołączonej gąbki.

23

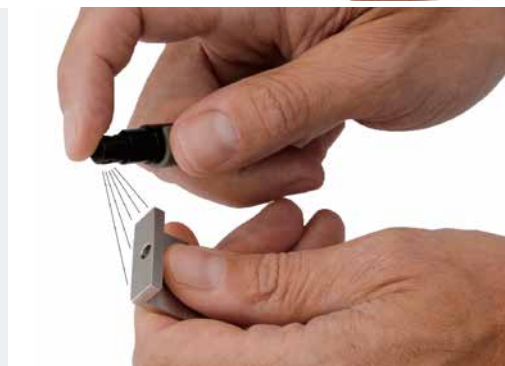

Wyczyścić z wykorzystaniem spryskiwacza ręcznego.

24



Dokładnie osuszyć uchwyt przed nałożeniem kleju.

25



Natożyć warstwę kleju o grubości ok. 3-5 mm.



MONTAŻ NA POWIERZCHNIACH INNYCH NIŻ GLAZURA

W razie potrzeby uchwyt ścienny można przymocować śrubą. W przypadku montażu górnej szyny do powierzchni, do której nie przywiera klej, takiej jak na przykład ściana malowana, konieczne jest wykorzystanie śrub.

26



Przeciągnąć matym „grzebykiem”, aby uformować paski w warstwie kleju.

27



Aktywować klej poprzez bezpośrednie naniesienie płynu spryskiwaczem ręcznym.

28

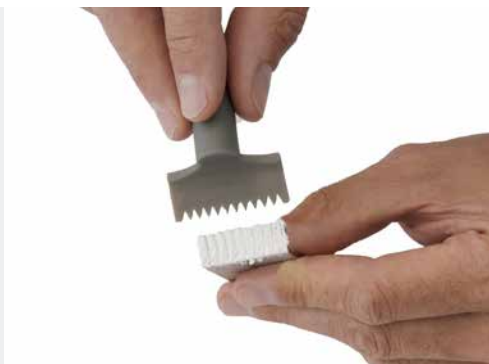

Kilka razy przeciągnąć „grzebykiem” warstwę kleju i płynu, aby skutecznie wymieszać oba składniki.

29

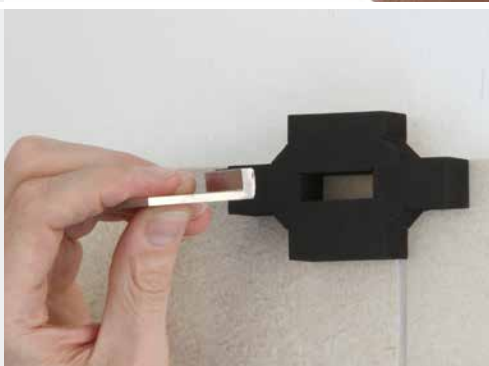

Docisnąć uchwyt ścienny do glazury przez otwór w bloku piankowym. Blok piankowy utrzyma uchwyt nieruchomo do czasu wyschnięcia kleju.
UWAGA: całkowite utwardzenie kleju trwa 72 godziny, ale szynę można ostrożnie zamontować już po 24 godzinach.

KOŃCZENIE MONTAŻU

30



Po odklejeniu bloku piankowego widoczne mogą być wycieki nadmiaru kleju, które należy usunąć skrobakiem lub nożem z łamanym ostrzem.

31



Nasunąć górną szynę ostrożnie na uchwyt ścienny.

32

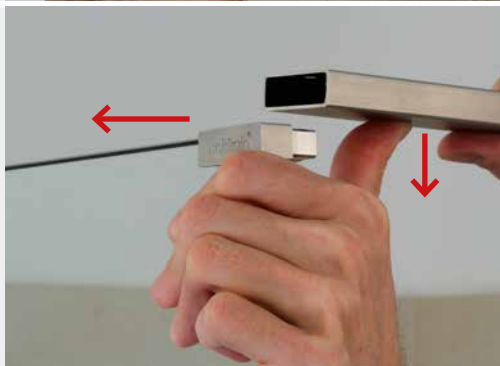

Odciągnąć ścianę prysznicową, aby umożliwić wsunięcie szyny w odpowiednie miejsce.

33

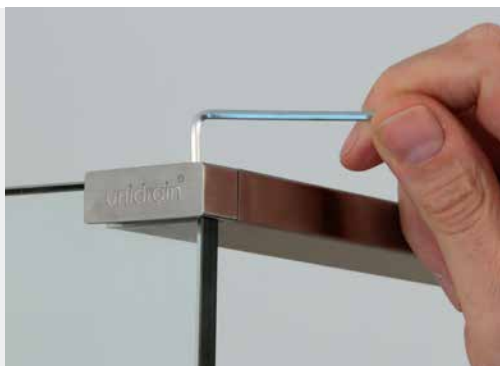

Przykręcić górną śrubę.

34



Na drugim końcu włożyć śrubę dociskającą i dokręcić ją.

35



Górną szynę jest teraz zamontowana.

